

PURO MIDI

Oil/water separator for compressors capacities up to 750 SCFM



PRODUCT FEATURES

The PURO is designed to separate oil from condensate that is extracted from compressed air systems. The PURO MIDI condensate separator covers compressor capacities up to 750 SCFM. The PURO MIDI's capacity can be increased by adding the XTENDER. By doing this, the PURO MIDI's compressor capacity is brought up to 1400 SCFM.

Like in all PURO models, the high performance white element offers true separation benefits which are unrivalled.

COMMERCIAL BENEFITS

- Separation of all types of compressor lubricants
- Compact design
- TEST valve and kit feature to test oil ppm residue
- The PURO does not incorporate a settling reservoir (no bacteria growth)
- Clothing kit included.

TECHNICAL ADVANTAGES

- Any type of condensate drain can be applied.
- No de-rating required.
- Modular add-on possibilities.
- Easy serviceable/maintenance.

PRODUCT DIMENSIONS

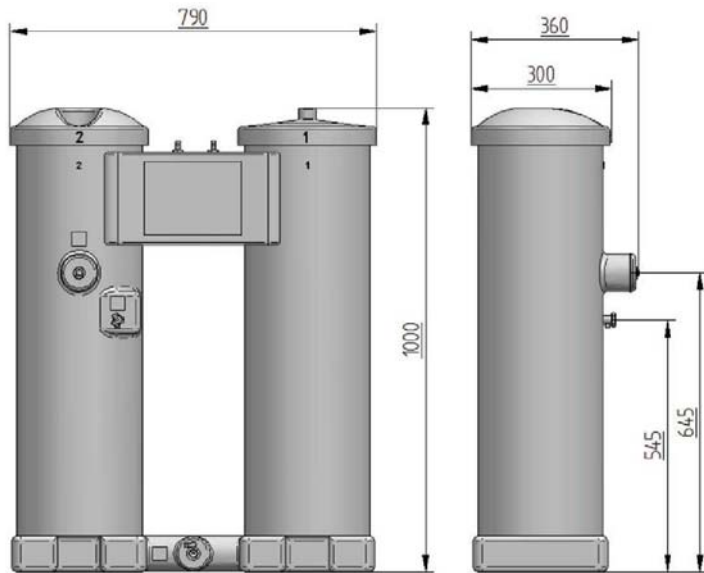

25.4MM=1"

PRODUCT SPECIFICATIONS

Compressor capacity	20m ³ /min (750 CFM)
Max. oil adsorption white element	4 Gallons
High performance white element	1
Activated carbon element	1
Inlet connection	1/2" (2 Each)
Outlet connection	1/2"
TEST valve	Yes
Housing material	PE
Total recyclable	Yes
Housing color	Ral 7026
Lid color	Ral 7021
Weight	110 Lbs. Can Ship UPS

PRODUCT FEATURES



TEST feature
TEST kit
included



Overflow indicator



All threads are brass
inserts and the hose
pipe connectors are
included.



Helpful lifting
handles on
the elements