

# PURO MINI

Oil/water separator for compressors capacities up to 125 SCFM



## PRODUCT FEATURES

The PURO MINI is designed to separate oil from condensate that is extracted from compressed air systems. The PURO MINI condensate separator covers compressor capacities up to 125 SCFM.

The separation method of the PURO MINI is the same as its larger family members and therefore offers true condensate separation values for the smaller compressor applications.

## COMMERCIAL BENEFITS

- Separation of all types of compressor lubricants
- Compact design (wall mounting bracket optionally available)
- TEST valve and kit feature to test oil ppm residue
- The PURO MINI does not incorporate a settling reservoir (no bacteria growth)
- Clothing kit included.

## TECHNICAL ADVANTAGES

- Any type of condensate drain can be applied.
- No de-rating required.
- Easy serviceable/maintenance.

**PRODUCT DIMENSIONS**

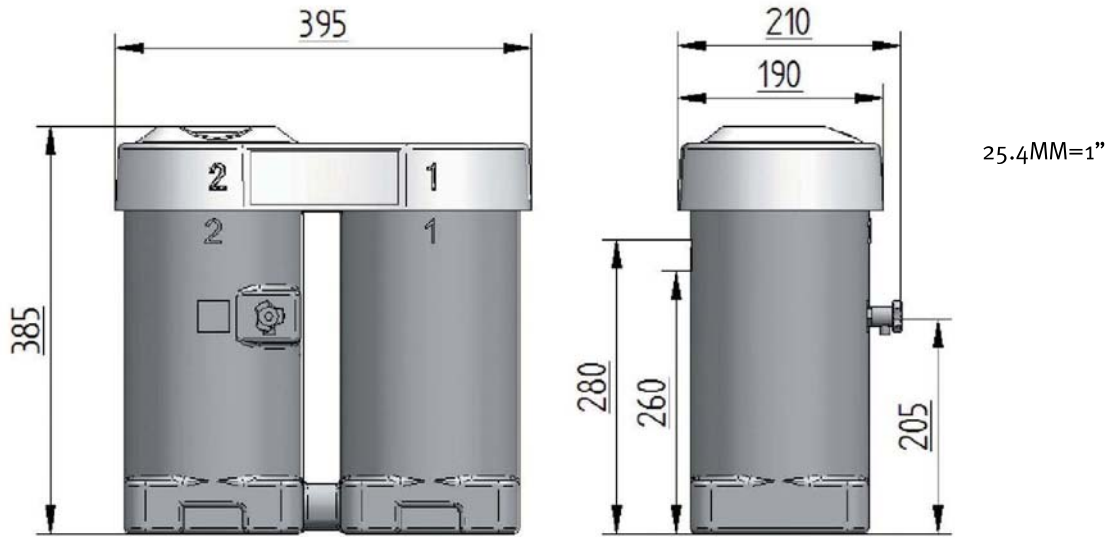

**PRODUCT SPECIFICATIONS**

Compressor capacity	3.5m <sup>3</sup> /min (125 CFM)
Max. oil adsorption white element	.8 Gallons
High performance white element	1
Activated carbon element	1
Inlet connection	1/2"
Outlet connection	1/2"
TEST valve	Yes
Housing material	PE
Total recyclable	Yes
Housing color	Ral 7026
Lid color	Ral 7021
Weight Empty	18 LBS. Can Ship UPS

**PRODUCT FEATURES**



TEST feature



TEST kit included



All threads are brass inserts and the hose pipe connectors are included.



Compact design allows for cost effective shipping.